

COMMON

- Added accessories can affect a motorcycle's stability, performance and safe riding speed.

<Use and Care Information of the Carbon Parts Accessory>

- If there is any damage due to over turn, do not repair or reuse the parts.
- If parts are damaged, do not touch them with bare hands.

FRONT FENDER

FRONT FENDER

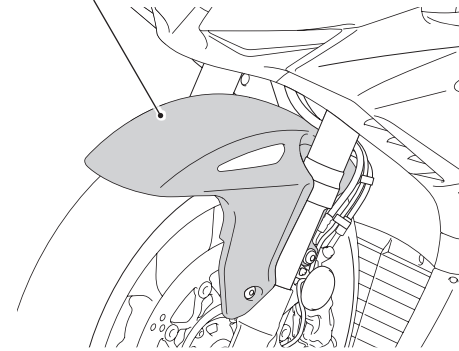

- Check the accessory mounts frequently.
- Clean this accessory with a soft cloth soaked with a solution of mild detergent and water. Then wipe with a clean cloth soaked with water to clean dirt and detergent. Finally wipe dry with a soft, clean cloth.

FENDER C

FENDER C

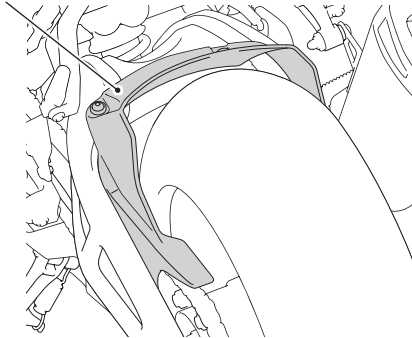

- Check the accessory mounts frequently and retighten if necessary.
- Clean this accessory with a soft cloth soaked with a solution of mild detergent and water. Then wipe with a clean cloth soaked with water to clean dirt and detergent. Finally wipe dry with a soft, clean cloth.

UNDER COWL

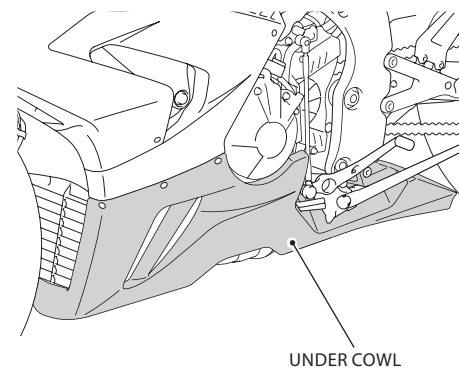

- Check the accessory mounts frequently.
- Clean this accessory with a soft cloth soaked with a solution of mild detergent and water. Then wipe with a clean cloth soaked with water to clean dirt and detergent. Finally wipe dry with a soft, clean cloth.

FRONT SHELTER

FRONT SHELTER

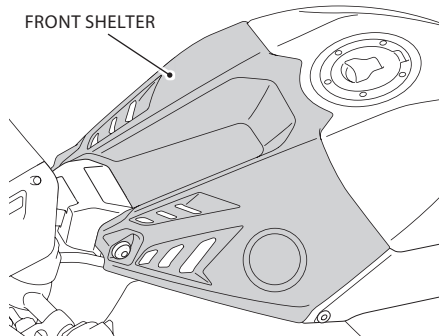

- Check the accessory mounts frequently.
- Clean this accessory with a soft cloth soaked with a solution of mild detergent and water. Then wipe with a clean cloth soaked with water to clean dirt and detergent. Finally wipe dry with a soft, clean cloth.

OIL FILLER CAP

OIL FILLER CAP

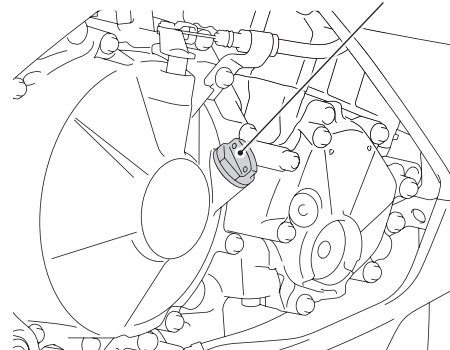

- Check the accessory mounts frequently and retighten if necessary.
- Clean this accessory with a soft cloth soaked with a solution of mild detergent and water. Then wipe with a clean cloth soaked with water to clean dirt and detergent. Finally wipe dry with a soft, clean cloth.

FRAME GUARD

FRAME GUARD

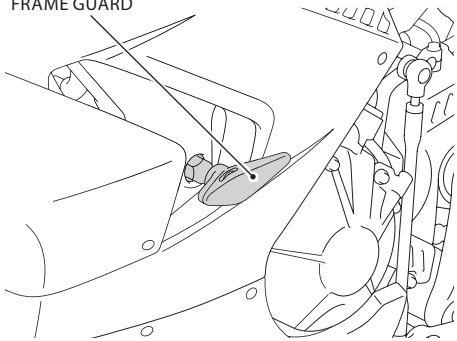

- Check the accessory mounts frequently and retighten if necessary.
- Clean this accessory with a soft cloth soaked with a solution of mild detergent and water. Then wipe with a clean cloth soaked with water to clean dirt and detergent. Finally wipe dry with a soft, clean cloth.

SEAT COWL

SEAT COWL

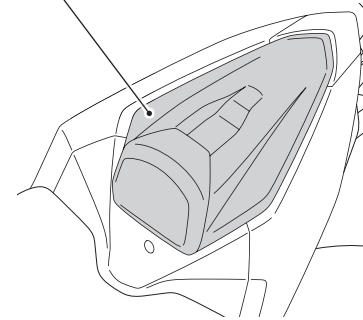

- Do not let anyone ride on the seat cowl and do not place luggage onto it.
- Check the accessory mounts frequently.
- Clean this accessory with a soft cloth soaked with a solution of mild detergent and water. Then wipe with a clean cloth soaked with water to clean dirt and detergent. Finally wipe dry with a soft, clean cloth.

SPROCKET PROTECTOR

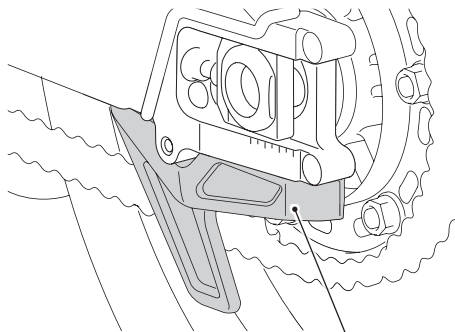

SPROCKET PROTECTOR

- Check the accessory mounts frequently and retighten if necessary.
- Clean this accessory with a soft cloth soaked with a solution of mild detergent and water. Then wipe with a clean cloth soaked with water to clean dirt and detergent. Finally wipe dry with a soft, clean cloth.

HIGH WINDSCREEN

HIGH WINDSCREEN

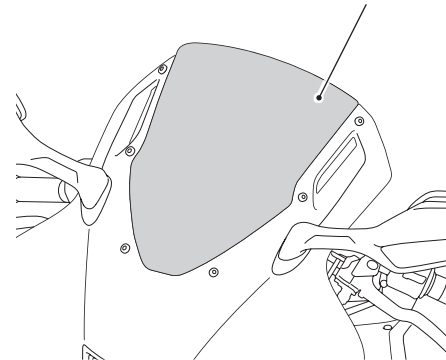

- Handle this accessory with care. It can be damaged when it is bent excessively or is subject to strong shock or impact.
- Park the motorcycle in the shade when it is to be left unattended in the summer for an extended period of time with a body cover placed over it.
- Failure to observe this precaution can cause this accessory to be deformed due to heat built up under the body cover.
- Select a firm, level surface when you park the motorcycle. Also bear in mind that strong wind can cause the motorcycle to topple to the ground.
- Check the accessory mounts frequently.
- When this accessory becomes dirty, rinse it thoroughly with cool water to remove loose dirt, then wipe with a clean cloth or sponge. Do not use a brush to clean this accessory as it may scratch the surface.
- Never use petroleum solvents such as gasoline, thinner or benzine to clean this accessory. Also do not use acid or alkaline cleaners.
- Wipe up spilled brake fluid at once as it may damage the plastic surface.

MAIN SEAT (ALCANTARA)

MAIN SEAT

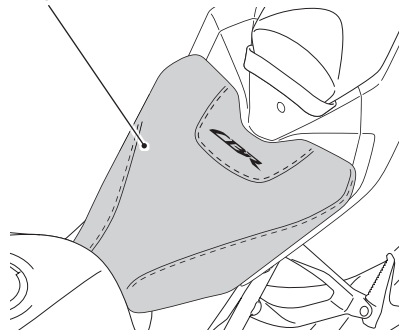

- Check the accessory mounts frequently.
- Clean this accessory with a soft cloth soaked with a solution of mild detergent and water. Then wipe with a clean cloth soaked with water to clean dirt and detergent. Finally wipe dry with a soft, clean cloth.

TANK PAD

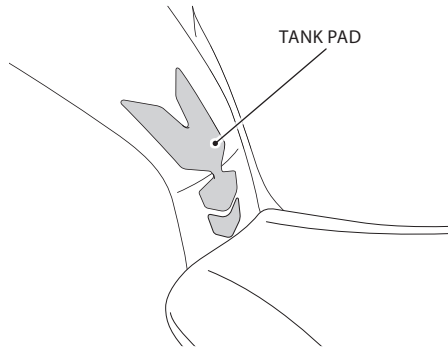

- Check the accessory mounts frequently.
- Clean this accessory with a soft cloth soaked with a solution of mild detergent and water. Then wipe with a clean cloth soaked with water to clean dirt and detergent. Finally wipe dry with a soft, clean cloth.

QUICK SHIFTER (CBR1000ST ONLY)

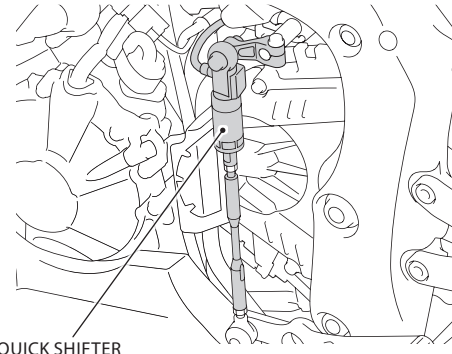

- Check the accessory mounts frequently and retighten if necessary.
- Clean this accessory with a soft cloth soaked with a solution of mild detergent and water. Then wipe with a clean cloth soaked with water to clean dirt and detergent. Finally wipe dry with a soft, clean cloth.

WHEEL STRIPE

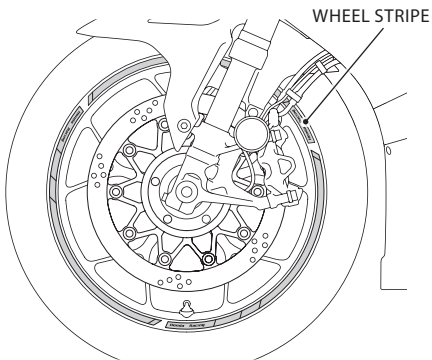

- Check the accessory mounts frequently.
- Clean this accessory with a soft cloth soaked with a solution of mild detergent and water. Then wipe with a clean cloth soaked with water to clean dirt and detergent. Finally wipe dry with a soft, clean cloth.

HOW TO USE THE QUICK SHIFTER

- This accessory enable the shift change without clutch operation when shifting up and down during acceleration. (Engine speed is more than 1,500 rpm on upshifting or more than the idle speed on downshifting).
- For setting the UP LVL or DOWN LVL of the Quick Shifter, make sure that you read the motorcycle Owner's Manual as well.

USB (TYPE-C) ATTACHMENT

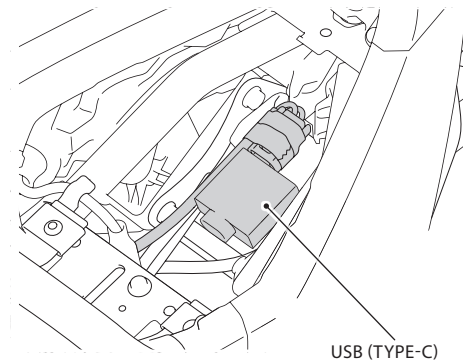

- The maximum power rating of connected accessories is 5V 3A.
- Use accessories with the engine running to avoid discharging the battery.
- Carefully secure any connected devices, as vibrations may cause them to shift unexpectedly.
- Check the accessory mounts frequently.
- Clean this accessory with a soft cloth soaked with a solution of mild detergent and water. Then wipe with a clean cloth soaked with water to clean dirt and detergent. Finally wipe dry with a soft, clean cloth.

TANK BAG

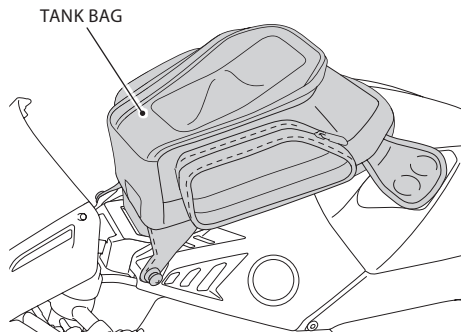

- The weight of the cargo must not exceed the following maximum load capacity:
Tank bag 2.0 kg (4.4 lb)
- Check the accessory mounts frequently and retighten if necessary.
- Clean this accessory with a soft cloth soaked with a solution of mild detergent and water or a cleaner.
- Do not store valuables or easily breakable items in the tank bag.
- Be sure that the fastener is closed securely before riding.
- The tank bag is not perfectly watertight, and water may enter when washing the motorcycle, or when it rains.

HOW TO INSTALL THE TANK BAG

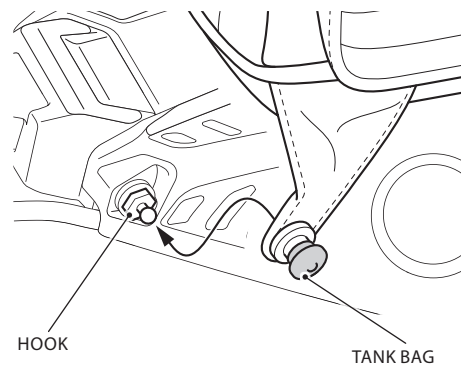

1. Install the tank bag as shown.
 - To prevent scratches, install the tank bag after wiping clean the top shelter and tank bag.
 - Repeat on the right side.

Secure the tank bag with the hook.

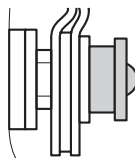

HOW TO USE THE RAIN COVER

RAIN COVER

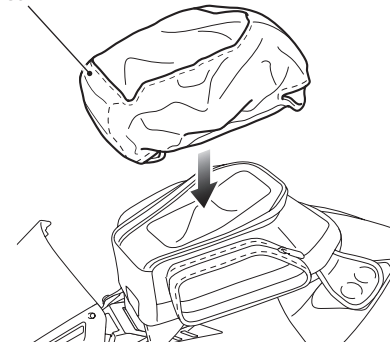

1. Cover the rain cover as shown.

Pass tank bag mounting part through the rain cover holes as shown.

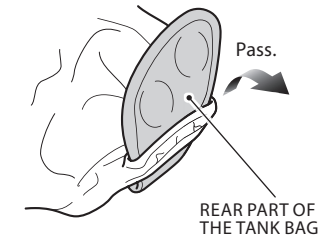
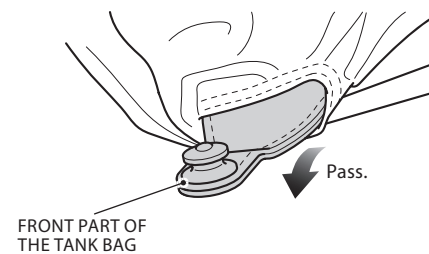

REAR SEAT BAG



- The weight of the cargo must not exceed the following maximum load capacity:
Seat bag 4.0 kg (8.8 lb)
- Check the accessory mounts frequently.
- Clean this accessory with a soft cloth soaked with a solution of mild detergent and water or a cleaner.
- Do not store valuables or easily breakable items in the seat bag.
- Be sure that the fastener is closed securely before riding.
- The rear seat bag is not perfectly watertight, and water may enter when washing the motorcycle, or when it rains.

HOW TO USE THE RAIN COVER

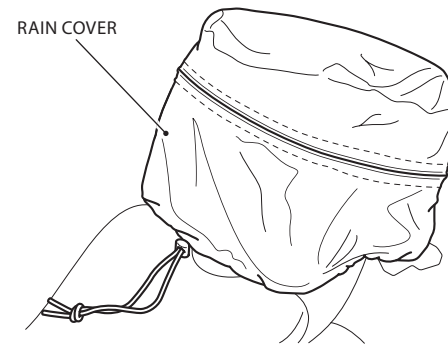

1. Cover the rain cover securely as shown.

<When extended the rear seat bag>

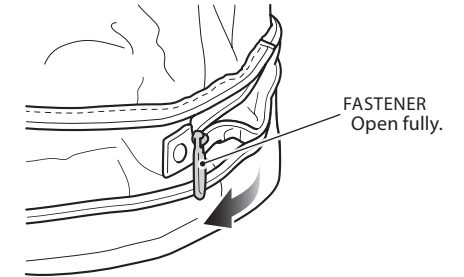

HOW TO INSTALL THE REAR SEAT BAG

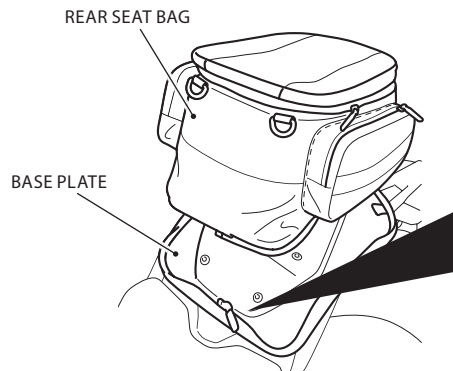

1. Install the rear seat bag as shown.
 - Make sure that the base plate is locked securely on the motorcycle.

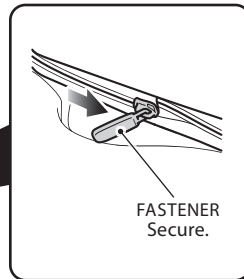

HOW TO USE THE EXTENDED REAR SEAT BAG



1. Open the fastener and pull up the rear seat bag as shown.

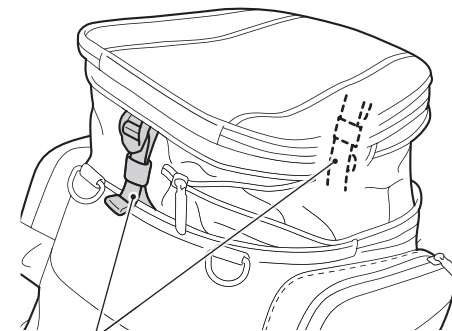

HOW TO USE THE REAR SEAT BAG

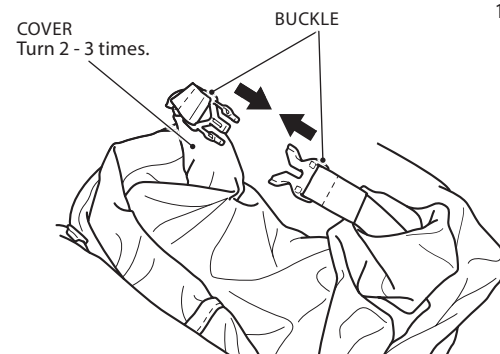

1. Turn the cover and lock the buckle as shown.

SAFETY INFORMATION

The following sentences show the label meaning.
Some labels warn you of potential hazards that could cause serious injury.
Others provide important safety information.
Read this information carefully and don't remove the label.

If a label comes off or becomes hard to read, contact your Honda dealer for a replacement.

There is a specific symbol on each label. The meanings of each symbol and label are as follows.



Read the use and care information in installation instructions or genuine accessory user's guide carefully.
Read the LOAD LIMITS AND GUIDELINES, and TYRES sections in owner's manual.



DANGER (with RED background)
You **WILL** be KILLED or SERIOUSLY HURT if you don't follow instructions.
WARNING (with ORANGE background)
You **CAN** be KILLED or SERIOUSLY HURT if you don't follow instructions.
CAUTION (with YELLOW background)
You **CAN** be HURT if you don't follow instructions.

Refer to this information for the meanings of the symbols shown on the accessory.

SCREEN WARNING LABEL

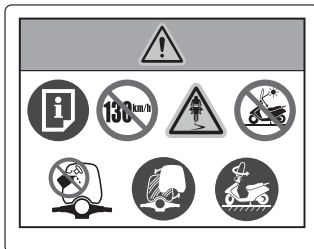

Never ride a motorcycle equipped with accessories and a cargo at speeds above 130 km/h (80 mph).



Added accessories and cargo can reduce a motorcycle's stability, performance and safe riding speed. A motorcycle's stability is influenced by an improper loading, worn or under-inflated tyres, the overall motorcycle condition and environmental conditions.



Do not park the motorcycle with the sun shining on the backside of the unit; the reflection may damage the motorcycle parts.



Never use organic solvents such as gasoline, thinner and benzene to clean this accessory. Also do not use acid or alkaline cleaners to clean.



Replace the windshield if clear vision is obstructed.



Select a firm, level surface when you park the motorcycle.
Also bear in mind that strong wind can cause the motorcycle to fall to the ground.